



INSTRUCTION MANUAL
TCX
Thermocouple Transmitter

Form 107-701-00D

April 2016

GENERAL INFORMATION

1.0 SCOPE OF MANUAL

This manual contains descriptive, adjustment, operating and maintenance information for the model TCX 2-wire Thermocouple Transmitter, manufactured by MOORE INDUSTRIES INC., Sepulveda, California. The manual consists of the following six sections:

Section 1, Description, introduces the equipment's function and describes its physical appearance, specifications, and options available for the unit. This section also explains how to use the MOORE INDUSTRIES model numbering system.

Section 2, Adjustment/Calibration, provides all the information necessary to adjust the unit before installation. This section contains a list of the tools necessary for adjusting the equipment and illustrates the test setups essential to performing that task. It also suggests methods for calibrating the unit.

Section 3, Installation and Operation, supplies information needed to install and operate the equipment. This section contains figures that detail the installation requirements for the unit, and text that informs the user of recommended wiring practices and defines the electrical connections for each unit regardless of physical configuration. A brief outline of periodic inspection routines, recommended for continuing operation, is also included.

Section 4, Theory of Operation, gives a brief description of the circuit operating principles in connection with a simplified block diagram, to illustrate the method used to process signals through the unit. This helps the user to isolate malfunctions to a particular piece of system equipment.

Section 5, Maintenance, applies to field operations. It points out areas that should be protected from environmental contamination and extremes of temperature. Inspection procedures are defined where recommended. Go-no-go test measures are described where appropriate, for use in diagnosing malfunctions.

Section 6, Unit Documentation, contains official company drawings which reflect current revisions of the unit as shipped.

The terms **NOTE**, **CAUTION**, and **WARNING** are each used with a specific meaning throughout this manual. A **NOTE** provides additional information that makes it easier to perform a particular task--for example, a step in wiring or disassembly. Failure to follow a **NOTE** may result in some inconvenience or needless expense, but the unit will not be damaged, nor is the instrument technician likely to be injured. A **CAUTION** stresses important details to follow--when making electrical connections or cleaning PC board contacts--for example. Failure to heed a **CAUTION** may damage the unit, void the Moore Industries warranty, or even result in minor physical injury to the instrument engineer or technician. A **WARNING** provides vital safety information which must not be ignored on any account. **WARNINGS** deal with proper grounding of equipment, use of solvents, etc. More important than the damage that will certainly result to the unit, the instrumentation engineer or technician risks serious personal injury, or even death, if **WARNINGS** are not heeded.

1.1 EQUIPMENT DESCRIPTION

The TCX is a two-wire thermocouple transmitter. When connected in series with a 12-42Vdc power source and a resistive load, it converts millivolt input from any standard ISA thermocouple to a proportional output current. The output is a standard 4-20mA analog process signal. Optional 10-50mA is also available.

The TCX is suitable for interfacing with a process controller, a recorder or visual monitor. It maintains the output loop current at a level proportional to the thermocouple millivolt equivalent of measured temperature, regardless of ambient temperature changes. This is accomplished through the use of an automatic reference junction compensator bridge, which is custom adjusted for each type of thermocouple. Unit specifications are detailed on the enclosed data sheet, No. 142-710-02, and the specific housing style purchased is documented in the enclosed Outline and Installation Drawing.

The TCX is available in three different models to provide all-around flexibility for various applications. The three models are described briefly as follows:

The **TCX/HP** is designated the "Hockey Puck" and consists of a printed circuit assembly made up of three PC boards. PC1 and PC3 are stacked horizontally and hold all the electronic components. PC2, a small board mounted vertically across the center of

PC1, provides contacts for the plug-in, screw-clamp terminal block on the front of the unit. The PC assembly is enclosed in a protective aluminum housing with external controls for SPAN and ZERO adjustment.

The **TCX/PC** "Plug-In" module is electrically similar to the HP module. However, in the PC module, one end of the printed circuit board has a standard 6-pin male edge connector which accommodates all of the input-output functions of the unit. The other end of the board has a miniature front panel with SPAN and ZERO controls. A removable plastic safety cover protects the PC board and components. When the TCX/PC is purchased without an RMR or SMR (11-position card racks), the user must provide a 6-pin connector (Viking part No. 2VK155/1/2 or equivalent) to interface with the PC edge connector.

The **TCX/DIN** is a compact 2-wire Thermocouple Transmitter that mounts on a DIN rail. Its narrow width lends the unit to high density installations. This model snaps onto and off of a DIN rail which in turn is mounted on a wall, in a rack or in a standard NEMA enclosure. In other respects it is electrically and functionally equivalent to the HP and PC models except that it has RFI immunity as a standard feature.

The HP and DIN modules have the thermocouple TEMPERATURE COMPENSATION RESISTOR built into the enclosure, whereas the PC module requires that this resistor be installed on the barrier terminal strip of the card rack into which the module is inserted.

Explosion-Proof Unit

The explosion-proof enclosure option consists of the standard HP module inserted into a two-piece cast aluminum alloy enclosure. The two pieces consist of a screw-type cover and housing with hubs. The standard enclosure is modified mechanically, to allow mounting of the HP housing into the explosion-proof housing. The modification consists of an additional spring assembly that wedges the standard unit into place.

RF Unit Physical Description

The -RF option consists of standard TCX electronics with the addition of an RF filter input. This additional electronic process requires some mechanical modifications to the input connections. An RF filter replaces the standard input connector, with the input and output connections being effected through a flexible cable wired between the PC board and filter. This configuration mechanically fastens the housing cover to the PC board; thus, both assemblies must be removed together for maintenance.

1.2 SPECIFICATIONS

Refer to Section 6, which contains a complete set of specifications for the TCX. This specification sheet contains complete information on input, output, performance capability and both mechanical and electrical options available.

1.3 MODEL NUMBER, EXPLANATION AND USE

MOORE INDUSTRIES model numbers identify an instrument's type, functional characteristics, operating parameters, and any options ordered. If all accompanying documentation for a unit is missing, the model number can be used to obtain technical information on the unit by following the example in Table 1-2. On HOCKEY PUCK units, the model number is stamped on the stainless steel tag fastened to the face of the unit. On DIN units, the model number is located at the lower edge of the front panel. For PC modules, the model number is located on the inside of the grip extension on the front panel.

1.4 SERIAL NUMBER USE AND LOCATION

A complete history is kept on every MOORE INDUSTRIES unit. This information is keyed to the serial number. Whenever factory service data are required on a unit, it is necessary to provide the factory with the serial number as well as the model number. This information is usually located with the model number, as discussed in paragraph 1.3 above.

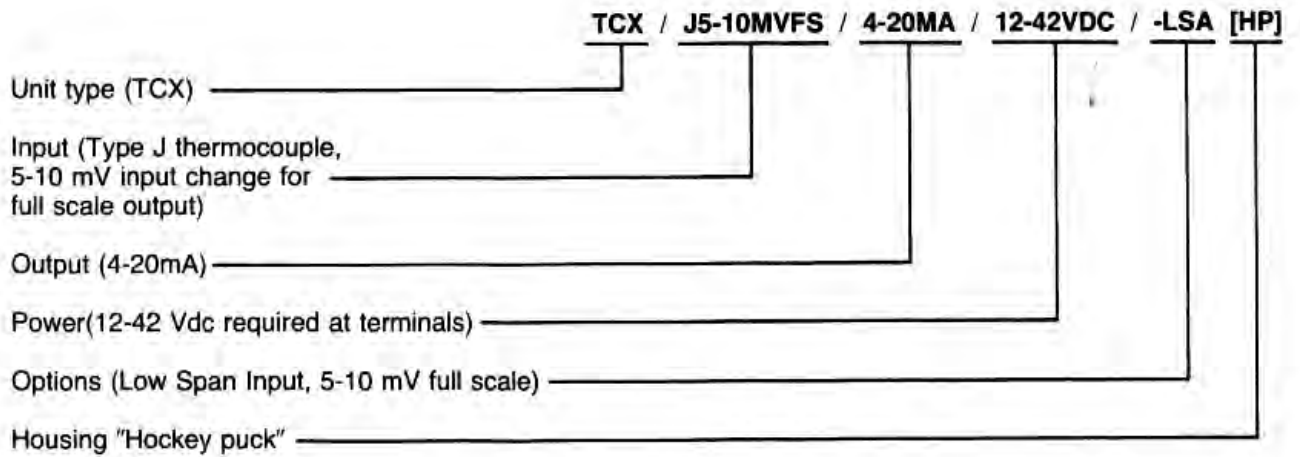

**TABLE 1-2
MODEL NUMBER EXAMPLE**

OPTION DESCRIPTION	CODE
Elevated Zero, "X" = mV offset, required on all units exceeding zero adjustment capability	EZX
Factory Calibration	FC
Patented terminal strip with filters and ground plane for RFI/EMI protection, exceeds SAMA standard PMC 33.1 d	RF
Low Input Span, 5-10 mV full scale (Calibration Capability $\pm 0.25\%$ of span)	LSA

**TABLE 1-3
TCX ELECTRICAL OPTIONS**

CALIBRATION PROCEDURES

2.0 INTRODUCTION

This section explains how to check out and adjust the Model TCX transmitter. Units with standard input and output are checked for proper performance at the factory before shipment. However, after the unit is unpacked, a general operating level test or check-out of the instrument is recommended. This check-out should require only minor adjustments, or none at all.

Units that have been special ordered with custom input and/or output are accurately adjusted at the factory before shipment. Though these units should be checked for proper performance, do not attempt to readjust them in the field. Notice that factory adjusted units have red "cal caps" installed on the pots to prevent tampering. If custom units do not perform as specified, contact the factory immediately.

CAUTION
DO NOT CHECK OUT OR ADJUST ANY UNIT UNLESS PROPER TOOLS AND TEST SETUP WITH CURRENT PROCEDURE ARE AVAILABLE AND UNDERSTOOD

2.1 CONTROLS: DESCRIPTION AND LOCATION

The external controls consist of ZERO and SPAN adjustments located on the front panel of the unit. Each control is a multiturn potentiometer that is adjusted with a blade screwdriver.

CAUTION
USE A BLADE SCREWDRIVER NOT MORE THAN 2.54mm (0.1 INCH) WIDE. A WIDER BLADE MAY PERMANENTLY DAMAGE THE POTENTIOMETER MOUNTING. WHEN ADJUSTING AN -RF OPTION UNIT, A SCREWDRIVER WITH A PLASTIC SHANK MUST BE USED. A METAL SHANK TOOL CAN CIRCUMVENT THE RF IMMUNITY AND COMPROMISE THE ADJUSTMENTS.

The ZERO and SPAN pots usually require 22 turns of the shaft to move the wiper from one end of its range to the other. The pot is equipped with a slip clutch at either end of its travel to prevent damage if it is turned beyond the wiper stop. Slightly more torque is required to turn the shaft when the clutch is slipping. If this change cannot be observed, however, either end of the pot can be reached by 22 turns of

the shaft in the desired direction. Clockwise on the control increases the quantity or makes it more positive. Counter-clockwise decreases the quantity or makes it more negative.

2.2 EQUIPMENT AND TOOLS

The necessary equipment and tools required to adjust and calibrate this unit are listed in Table 2-1. These things are not supplied and must be provided by the user at the installation or test site.

2.3 TEST SETUP

The general test setup necessary to check-out, adjust, or calibrate the TCX, regardless of configuration or options, is shown in Figure 2-1. Terminal connections are identified on the label next to the physical terminals and on the reverse side of the Outline and Installation Drawing included in Section 6 of this manual.

2.4 ADJUSTMENT

Adjustment consists of simulating an input signal to the TCX unit, monitoring the output, and adjusting the controls to obtain the desired values. Calibration is defined as the process of taking output readings from a properly adjusted instrument, when the input is stimulated by standard input signals over the range of interest, and tabulating or plotting the results to form a convenient correction chart for future measurements when the instrument is permanently installed. Calibration curves or charts are not provided by the factory unless specified at the time of purchase. Adjustments will be provided as standard, or set to special values, if specified at the time of purchase.

2.4.1 Preliminary Setup

When a millivolt calibrator is used to simulate a thermocouple signal, it must be connected to the TCX module using the same type of thermocouple wire that the system is designed to use. This is because the temperature compensation bridge circuit built into the module is customized by a computer matrix program for each thermocouple type and temperature range. The result is that the input signal will now consist of two parts: a) the millivolt level dialed in by the millivolt calibrator; and b) the millivolt level injected because of room temperature effect on the thermocouple junction formed at the millivolt calibrator terminals. It will be necessary to measure room

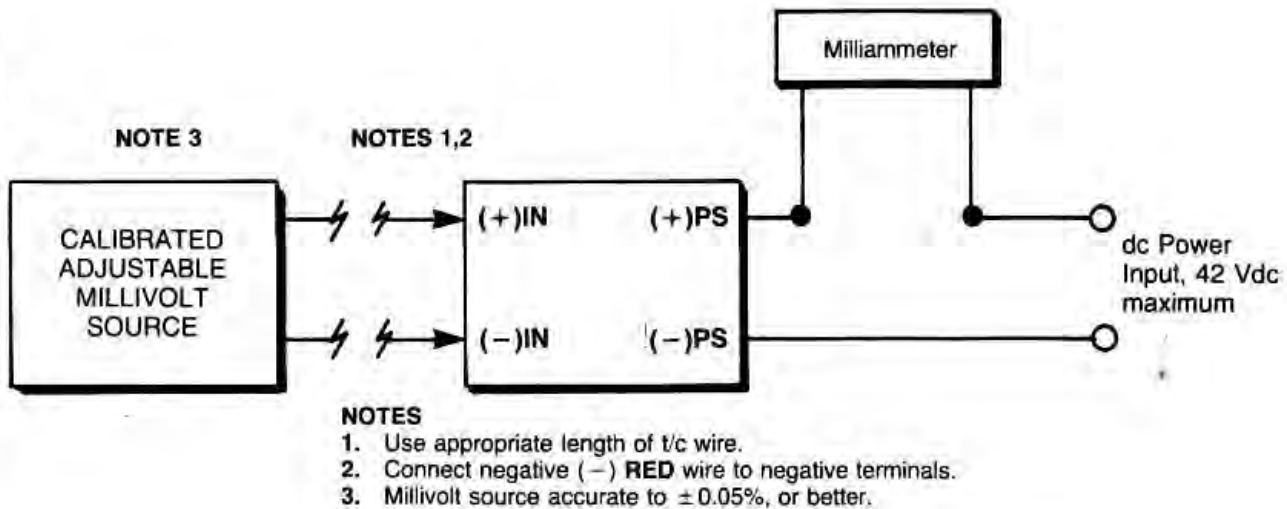

FIGURE 2-1
CHECKOUT / CALIBRATION TEST SETUP

temperature at the calibrator terminals during this test to calculate the total signal level that is being injected at the TCX input. For example, if the room temperature is measured to be 70°F and a type J thermocouple is being used, the thermocouple tables show that the millivolt level contributed by the thermocouple is +1.076mV. If it is then desired to set the SPAN control for 100% output (20mA for example) when the simulated process variable temperature is 400°F, the number of millivolts found in the table to represent 400° must be reduced by 1.076 millivolts when setting the millivolt calibrator for this temperature. This same compensation approach is required for any other temperature check points that might be used in verifying the module. If the room temperature changes at or near the calibrator terminals, then a new value for the thermocouple correction figure must be determined from the standard tables for the new room temperature.

2.4.2 Functional Testing

- Connect the unit to the millivolt source, using the same kind of thermocouple wire that will be used when the TCX is installed.
- Connect 12-42Vdc in series with a dc milliammeter ($\pm 0.05\%$ accuracy) to the positive (+) PS and negative (-) PS terminals on the TCX.
- Adjust millivolt source to zero. Apply power to the TCX and let the unit warm up for approximately 10 minutes.
- Use the thermometer to measure ambient air temperature at the millivolt source terminals.
- Using the published tables, compensate for the room temperature effect as described above and adjust the millivolt source accordingly for the inputs called out in steps F, H, and K.

- Adjust the millivolt source for a signal equal to the corrected T/C output at the lowest operating temperature.
- Use the milliammeter to monitor the TCX output and adjust the ZERO potentiometer for 0% output (4mA or 10mA).
- Adjust the millivolt source for a signal equal to the corrected T/C output at the highest operating temperature.
- Use the milliammeter to monitor the TCX output and adjust the SPAN potentiometer to 100% output (20mA or 50mA).
- Repeat steps F through I until no further adjustment of the ZERO and SPAN pots is necessary.
- Subtract millivolts in step F from millivolts in step H. Calculate 25%, 50%, and 75% of this difference. Add these amounts to the input used in step F and adjust the millivolt source accordingly.
- Observe the milliammeter reading for each of the inputs calculated in step K and verify that the output is linear within $\pm 0.1\%$ of the output range.

2.4.3. Option Checks

- EZX (Elevated Zero)**
These units are tested in the same manner, except that the EZ value should be substituted for 0mV in the preceding text.
- LSA (Low Input Span) 5-10mV Full Scale**
These units are tested in the same manner, but the calibration capability figure increases to $\pm 0.25\%$ of span.

EQUIPMENT OR TOOL	CHARACTERISTIC	PURPOSE
Screwdriver Blade	Blade not wider than 2.54 mm (0.1 inch)	To adjust ZERO and Span
Calibrated Adjustable Millivolt Source	Leeds and Northrup Millivolt Potentiometer, Catalog No. 8690, or equivalent, accurate to $\pm 0.05\%$ or better	To simulate t/c input
DC Milliammeter	Fluke 8600 A or equivalent accurate to $\pm 0.05\%$ or better	To monitor the output signal
T/C Wire	Appropriate for the type t/c that will be used	To connect millivolt source to TCX input
Power Supply	12-42 Vdc	To power the unit
Calibrated Thermometer	Must be corrected to $\pm .05\%$ At room temperature	Measure Ambient Temperature

**TABLE 2-1
TEST EQUIPMENT AND TOOLS REQUIRED**

INSTALLATION & OPERATION

3.0 INSTALLATION AND OPERATION

Installation consists of checkout, adjustment (if necessary), mechanical installation and electrical connections. Checkout and adjustment are detailed in Section 2, Adjustment Procedures.

3.1 MECHANICAL INSTALLATION

The Model TCX is available in various physical configurations, notably the Hockey Puck enclosure, the DIN rail mount and the Plug-in module. Installation information for the unit purchased can be found on the Outline and Installation Drawing contained in Section 6.

Although the units are designed to operate in free air, mounting them on a surface that will serve as a heat sink is recommended, if at all possible, especially if the ambient temperature is high.

Two different racks are available for installing the Plug-In (PC) module, one for mounting on a flat surface (SMR) and one for a standard 19" equipment rack (RMR).

3.2 ELECTRICAL CONNECTIONS

Connections to the TCX are made to the terminal block on the front of the unit for HP and DIN models. (Note: the DIN model option—FR has the terminal block on the rear surface.) For PC models, when using either the RMR or SMR card rack, the connections are made to barrier terminal strips on the front or back of the card rack. Use No. 6 eye lugs on the wires to be attached to these terminal strips. Terminal locations and pin functions for the unit purchased are identified on the Outline and Installation Drawing included in Section 6 of this manual.

The TCX requires a 12-42Vdc current loop power supply connected to the (+)PS and (-)PS terminals of the unit in series with the output load. Because the input and output are transformer isolated, the input can be either grounded or allowed to float with respect to the output. The temperature compensation sense resistor is incorporated into the terminal block for both the HP and DIN models. In the PC model, it must be connected to terminals 2 and 4 on the input terminal block as shown on drawing No. 107-551-00 in Section 6. See Figure 3-1 for typical hookup configurations.

3.2.1 Wiring Practices

Use the appropriate thermocouple extension wire to

connect the input signal to the TCX, if the unit is not mounted adjacent to the temperature source.

NOTE
OBSERVE PROPER POLARITY WHEN CONNECTING THE THERMOCOUPLE TO THE TCX. T/C WIRE WITH RED INSULATION IS THE NEGATIVE (-) WIRE. CONNECT IT TO THE NEGATIVE (-) IN TERMINAL OF THE TCX. CONNECT THE OTHER WIRE TO THE POSITIVE (+) IN TERMINAL OF THE TCX.

No special wire or cable is required to complete power and signal output connections. However, when installing the HP, or DIN configuration, it is recommended that No. 20 AWG wire be used to connect to the compression screw terminals used on these models. No terminating lugs are necessary for this type of terminal. Simply strip the insulation from the end of the wire, tin the ends with 60/40 solder, insert in the terminal socket and tighten the screw.

3.3 OPERATION AND PERIODIC INSPECTION

Once adjusted and installed, the unit can be operated unattended. The only controls on the outside of the unit are the SPAN and ZERO potentiometers, which, after initial adjustments, need no further attention. There are no indicators on the unit and because the circuit uses highly reliable solid-state components with no moving parts, the TCX will operate virtually maintenance free for extended periods of time. If, however, at a future time, a malfunction is isolated to the TCX transmitter, refer to Section 5 for recommendations on solving the problem.

A unit may become warm during operation, especially where the ambient temperature is above normal. This is perfectly acceptable and should not be cause for alarm unless a malfunction is also observed.

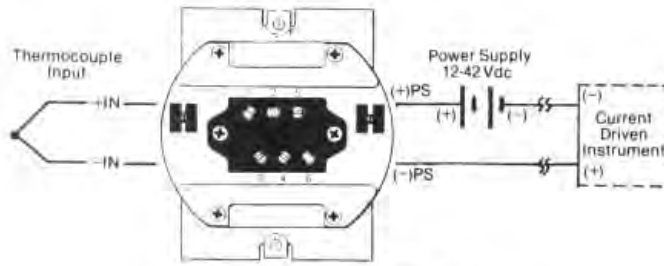

**TCX CONNECTION
USING SEPARATE**

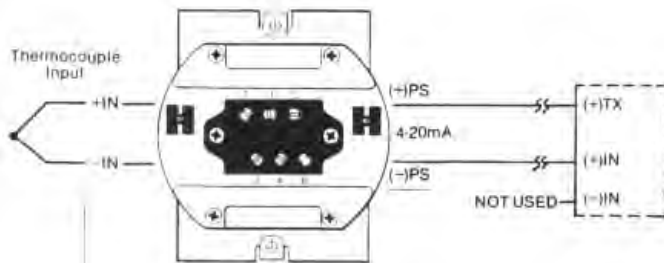

CONNECTION WITH TX OPTION

**FIGURE 3-1
TYPICAL HOOKUP CONFIGURATIONS**

THEORY OF OPERATION

4.0 INTRODUCTION

This section describes the theory of operation of the TCX based on the simplified schematic diagram in Figure 4-1. A detailed schematic diagram can be found in Section 6, Unit Documentation. The purpose of this description is to show how signals are processed through the unit should it become necessary to troubleshoot the data loop to isolate a malfunction to a particular piece of equipment.

4.1 OPERATION

The TCX accepts ISA standard thermocouple millivolt input signals and generates a proportional 4-20mA, 2-wire loop current output when energized by a 12-42Vdc power source. Reference junction temperature compensation is provided over the specified operating temperature range by an accurately selected resistive temperature sensor in a computer optimized bridge input circuit.

The compensated input signal is fed through a preamplifier to a FET chopper which then couples it to the primary of an isolation transformer. The preamp includes both OP AMP IC301 and FET Q301, to convert the millivolt input signal to a proportional current sink for the primary center tap of isolation transformer T-2. The power supply circuit utilizes a free running multivibrator to produce the chopper and demodulator functions across the isolation transformer as well as to provide dc excitation for the solid state devices on the input side of the isolation transformer.

Synchronous demodulation is provided for the isolation transformer secondary by FETs Q1 and Q2 which furnish the input for the active filter IC1. With the chopper operating at approximately 5KHz, this filter easily removes the transition spikes leaving a smooth analog of the thermocouple input. This signal then provides the input for the two-stage discrete transistor output current driver. (Q3 and Q4)

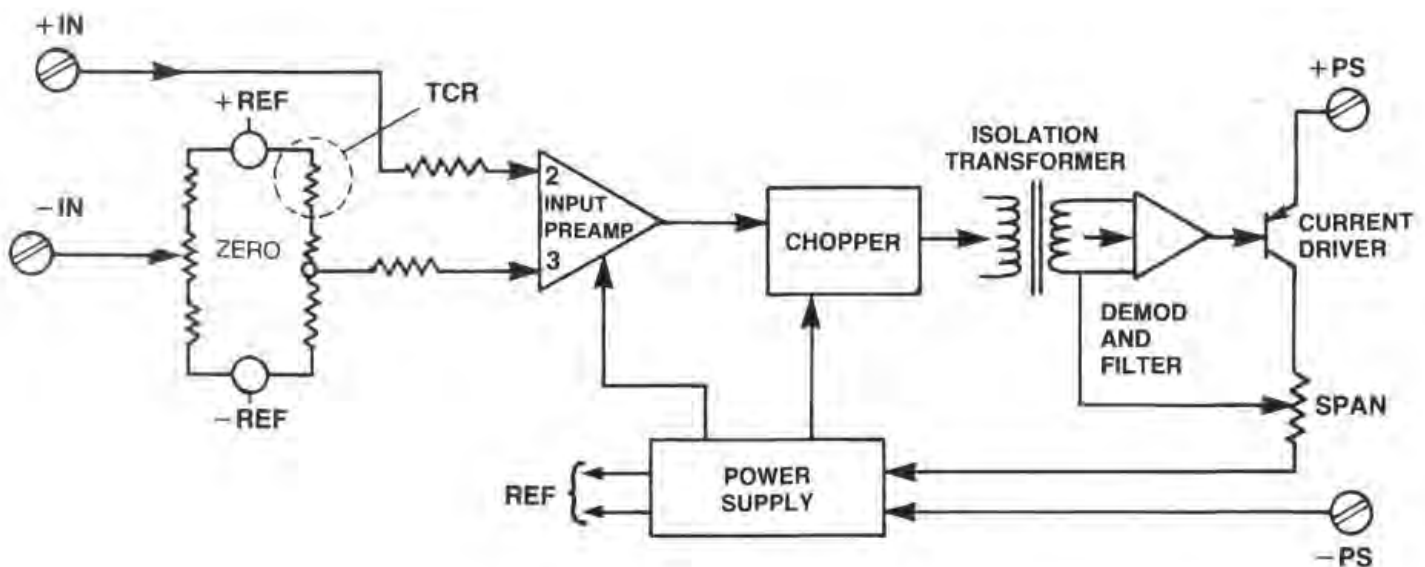

FIGURE 4-1
SIMPLIFIED SCHEMATIC DIAGRAM

MAINTENANCE & TROUBLESHOOTING

5.0 MAINTENANCE

To achieve and maintain the high level of performance built into the Moore Industries signal transmitters, many components have been group selected using a computer-aided design program. This makes field repair generally inconsistent with maintaining performance as set forth in the included specifications. It is therefore recommended that any unit found to be performing below specifications be returned to the factory for service in accordance with the instructions found on the inside of the back cover of this manual. If the urgency of repair does not allow time to send the unit back to the factory for service, then it is recommended that the user contact the Moore Industries Customer Service department at the number shown on the inside of the back cover of this manual for verbal assistance in diagnosing the problem and making emergency repairs.

The design of the TCX temperature transmitter limits maintenance primarily to keeping the input and output terminals and conductors clean and tight and maintaining a good heat conduction path to a suitable heat sink. This is best accomplished by initially tinning the ends of all hookup wire, as called out in Section 3, and installing the unit in an area protected from dust, heat, moisture and corrosive atmospheres. A thorough cleaning of terminal blocks requires complete disassembly and can be accomplished only at the factory. It is recommended that the user check the terminations every 6 months of service for tightness and cleanliness.

5.1 PC MODEL CONNECTOR CLEANING

Occasionally, modules which have been in service for a long period of time develop a resistive coating on the gold-plated contacts of the plug-in boards. This coating, if allowed to build up, may cause malfunctions by decreasing the noise margin of a circuit.

This contamination involves organic substances, which usually result from careless handling and are mainly made up of fingerprints, salts, and oils deposited when the plug-in boards are handled by the gold-plated contacts. Contamination by organic substances can be greatly reduced by careful handling of the modules.

Although connectors are usually the self-cleaning type, it may become necessary to clean the module fingers to ensure reliable connection. Organic materials may be removed by immersion of contacts in trichloroethane for at least 30 seconds. Let contacts air dry or wipe with a very fine, nonabrasive material such as K-Dry towels or equivalent.

UNIT DOCUMENTATION

6.1 UNIT DOCUMENTATION

This section contains the following:

1. MOORE INDUSTRIES drawings for the current revision of the Model TCX 2-Wire Thermocouple Transmitter, as shipped.



MOORE INDUSTRIES
16650 Schoenborn Street
Sepulveda, California 91343

DO NOT SCALE DRAWING

TOLERANCES UNLESS NOTED
X ±.1
XX ±.03
XXX ±.010
ANGLES ±.30

DRAWN *W. H. King* 7/1/63
CHECKED
ENGINEER
SCALE

TCX DIN
PC3, PC2 & PC5

DRAWING NUMBER

107-409-00

REVISION

A

CATEGORY

SCHEMATIC

REVISED BY

INITIAL RELEASE

DATE

7/1/63

BY

JAD

APPROVAL

[Signature]

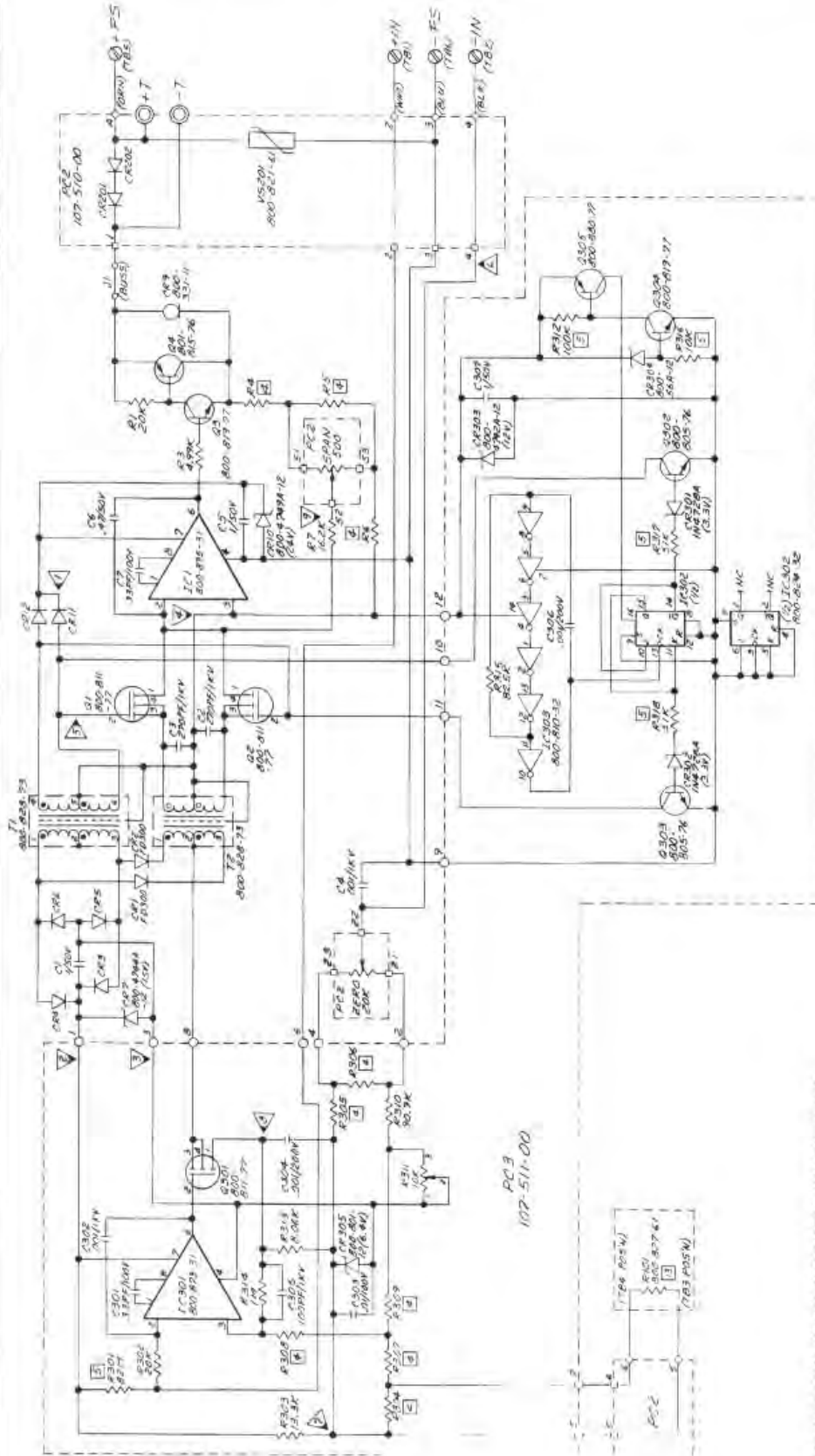

PC3
107-511-00

1. THIS DRAWING IS SUBJECT TO THE FOLLOWING CONDITIONS:
 - a. THIS DRAWING IS FOR PRODUCTION ONLY. FOR PRODUCTION TYPING, SEE THE DRAWING FOR THE PRODUCTION TYPING.
 - b. THIS DRAWING IS FOR PRODUCTION ONLY. FOR PRODUCTION TYPING, SEE THE DRAWING FOR THE PRODUCTION TYPING.
 - c. THIS DRAWING IS FOR PRODUCTION ONLY. FOR PRODUCTION TYPING, SEE THE DRAWING FOR THE PRODUCTION TYPING.
 - d. THIS DRAWING IS FOR PRODUCTION ONLY. FOR PRODUCTION TYPING, SEE THE DRAWING FOR THE PRODUCTION TYPING.
 - e. THIS DRAWING IS FOR PRODUCTION ONLY. FOR PRODUCTION TYPING, SEE THE DRAWING FOR THE PRODUCTION TYPING.
 - f. THIS DRAWING IS FOR PRODUCTION ONLY. FOR PRODUCTION TYPING, SEE THE DRAWING FOR THE PRODUCTION TYPING.
 - g. THIS DRAWING IS FOR PRODUCTION ONLY. FOR PRODUCTION TYPING, SEE THE DRAWING FOR THE PRODUCTION TYPING.
 - h. THIS DRAWING IS FOR PRODUCTION ONLY. FOR PRODUCTION TYPING, SEE THE DRAWING FOR THE PRODUCTION TYPING.
 - i. THIS DRAWING IS FOR PRODUCTION ONLY. FOR PRODUCTION TYPING, SEE THE DRAWING FOR THE PRODUCTION TYPING.
 - j. THIS DRAWING IS FOR PRODUCTION ONLY. FOR PRODUCTION TYPING, SEE THE DRAWING FOR THE PRODUCTION TYPING.
 - k. THIS DRAWING IS FOR PRODUCTION ONLY. FOR PRODUCTION TYPING, SEE THE DRAWING FOR THE PRODUCTION TYPING.
 - l. THIS DRAWING IS FOR PRODUCTION ONLY. FOR PRODUCTION TYPING, SEE THE DRAWING FOR THE PRODUCTION TYPING.
 - m. THIS DRAWING IS FOR PRODUCTION ONLY. FOR PRODUCTION TYPING, SEE THE DRAWING FOR THE PRODUCTION TYPING.
 - n. THIS DRAWING IS FOR PRODUCTION ONLY. FOR PRODUCTION TYPING, SEE THE DRAWING FOR THE PRODUCTION TYPING.
 - o. THIS DRAWING IS FOR PRODUCTION ONLY. FOR PRODUCTION TYPING, SEE THE DRAWING FOR THE PRODUCTION TYPING.
 - p. THIS DRAWING IS FOR PRODUCTION ONLY. FOR PRODUCTION TYPING, SEE THE DRAWING FOR THE PRODUCTION TYPING.
 - q. THIS DRAWING IS FOR PRODUCTION ONLY. FOR PRODUCTION TYPING, SEE THE DRAWING FOR THE PRODUCTION TYPING.
 - r. THIS DRAWING IS FOR PRODUCTION ONLY. FOR PRODUCTION TYPING, SEE THE DRAWING FOR THE PRODUCTION TYPING.
 - s. THIS DRAWING IS FOR PRODUCTION ONLY. FOR PRODUCTION TYPING, SEE THE DRAWING FOR THE PRODUCTION TYPING.
 - t. THIS DRAWING IS FOR PRODUCTION ONLY. FOR PRODUCTION TYPING, SEE THE DRAWING FOR THE PRODUCTION TYPING.
 - u. THIS DRAWING IS FOR PRODUCTION ONLY. FOR PRODUCTION TYPING, SEE THE DRAWING FOR THE PRODUCTION TYPING.
 - v. THIS DRAWING IS FOR PRODUCTION ONLY. FOR PRODUCTION TYPING, SEE THE DRAWING FOR THE PRODUCTION TYPING.
 - w. THIS DRAWING IS FOR PRODUCTION ONLY. FOR PRODUCTION TYPING, SEE THE DRAWING FOR THE PRODUCTION TYPING.
 - x. THIS DRAWING IS FOR PRODUCTION ONLY. FOR PRODUCTION TYPING, SEE THE DRAWING FOR THE PRODUCTION TYPING.
 - y. THIS DRAWING IS FOR PRODUCTION ONLY. FOR PRODUCTION TYPING, SEE THE DRAWING FOR THE PRODUCTION TYPING.
 - z. THIS DRAWING IS FOR PRODUCTION ONLY. FOR PRODUCTION TYPING, SEE THE DRAWING FOR THE PRODUCTION TYPING.

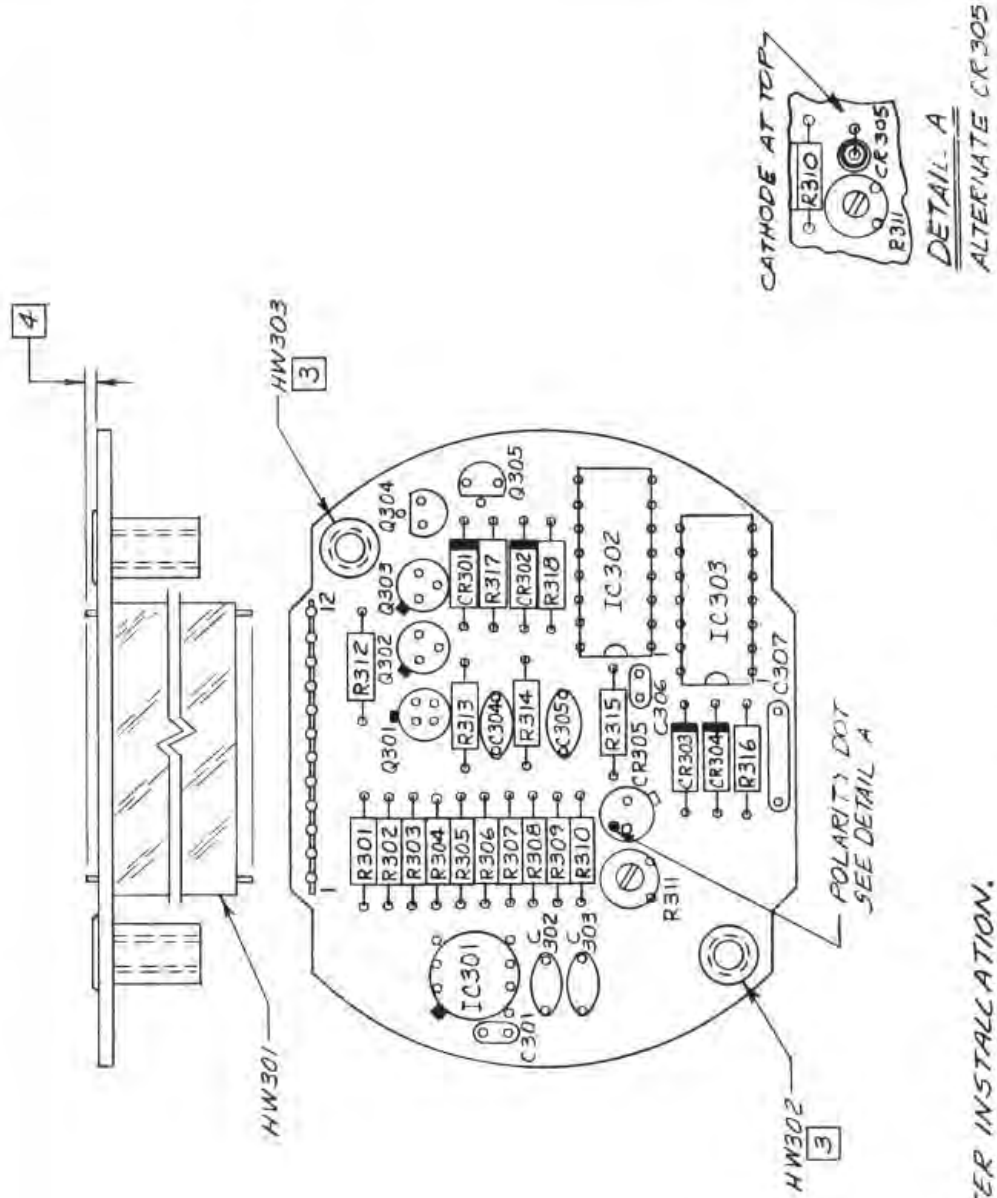

- 4 NOT TO EXCEED .05 AFTER INSTALLATION.
- 3 SWAGE FAR SIDE.
- 2 MAX. COMPONENT HEIGHT AFTER INSTALLATION NOT TO EXCEED .300.
- 1 ALL LEADS TO BE SOLDERED TO PADS.

NOTES:

DO NOT SCALE DRAWING

TOLERANCES
 UNLESS NOTED
 .X ±.1
 .XX ±.03
 .XXX ±.010
 ANGLES ±30°

DRAWN *R. Kelley* 7/24/83
 CHECKED
 ENGINEER
 SCALE 2-1

**TCX DIN
 PCI**

DRAWING NUMBER 107-509-00	REVISION B
CATEGORY ASSEMBLY	
REVISED BY <i>EOJ</i>	DATE <i>7/24/83</i>
BY <i>Art</i>	APPROVED

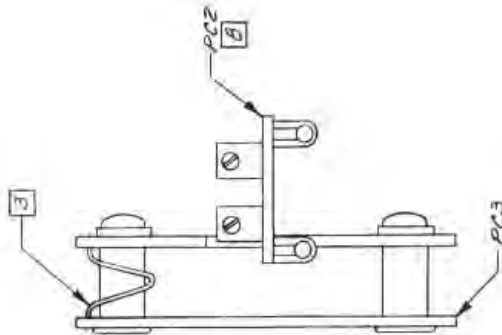
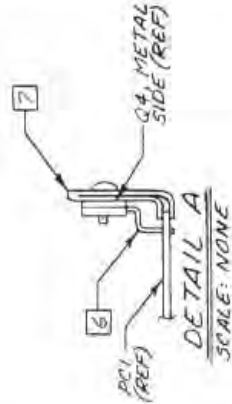
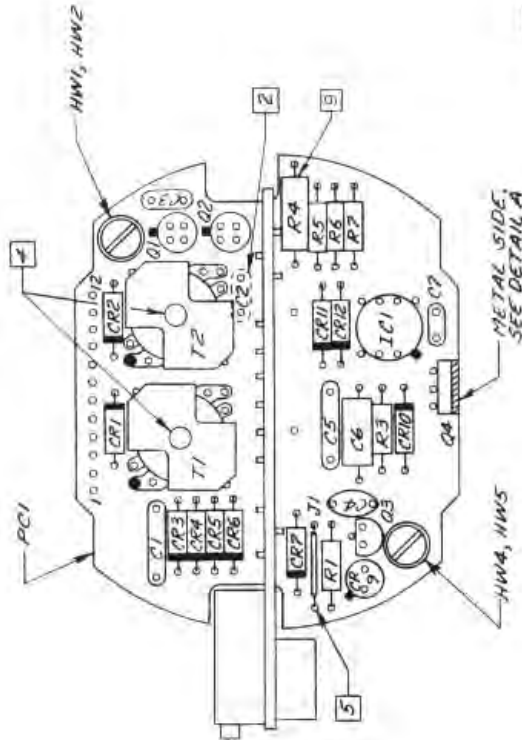
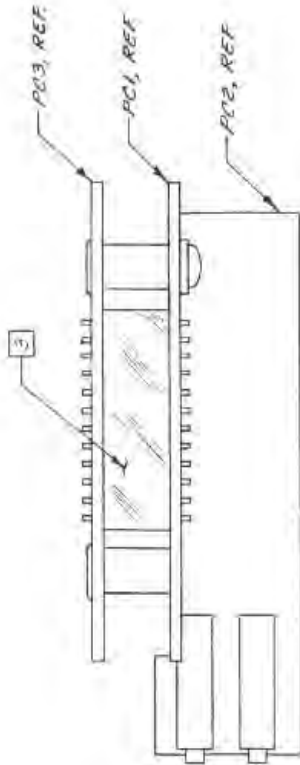

1. ELEVATE BODY OF R4 1/16" (MIN) ABOVE FE 1.
2. PC2 MUST SIT FLAT ON & PERPENDICULAR TO PCI.
3. USE FIXTURE 200-213-10 TO HOLD Q4 IN PLACE WHEN SOLDERING.
4. USE FIXTURE 200-213-11 FOR BENDING Q4 LEADS.
5. JUMPER IS 22-AWG BUSS, TEFLON SLEEVED.
6. INSTALL HW7 & HW8 BETWEEN PCI & T1, T2.
7. FLEX JUMPER STRIP COMES WITH PC3; BEND INTO PLACE APPROX. AS SHOWN.
8. C2 TO BE MOUNTED ON FAR SIDE OF PCI.
9. ALL LEADS TO BE SOLDERED TO PADS.

NO

MOORE INDUSTRIES
 18850 Scheephorn Street
 Sepulveda, California 91343

DO NOT SCALE DRAWING

TOLERANCES
 UNLESS NOTED
 X ±.1
 XX ±.03
 XXX ±.010
 ANGLES ±30°

DESIGNED BY *R Kelley*
 CHECKED BY
 DRAWN BY
 SCALE *2-1*

TCX DIN
PC2

ITEM NO. *107-510-00*
 REV. *B*

QUANTITY *ASSEMBLY*

PRICE BY *ECO # 5501*

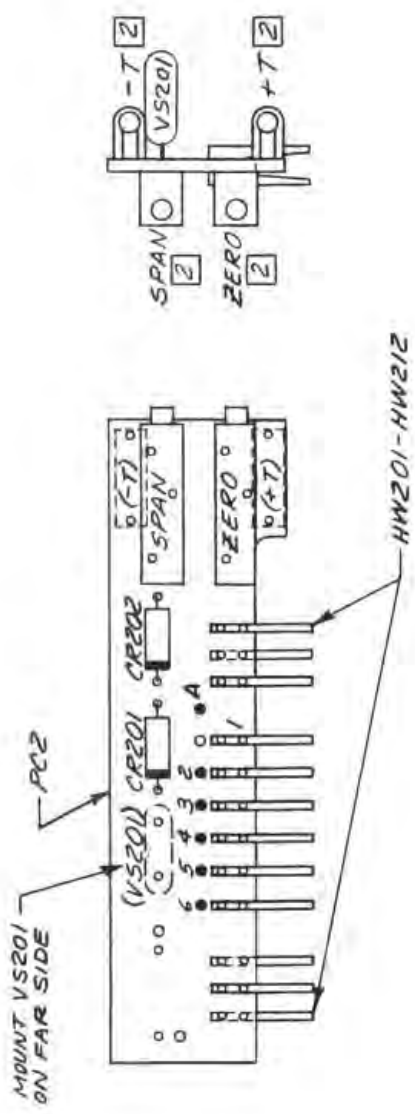

3. INSERT ALL WIRES FROM FAR SIDE OF PCB.
1. *SPAN, ZERO, +T & -T MUST MOUNT FLAT ON BOARD.*
1. ALL LEADS TO BE SOLDERED TO PADS.
- NOTES:

TCX

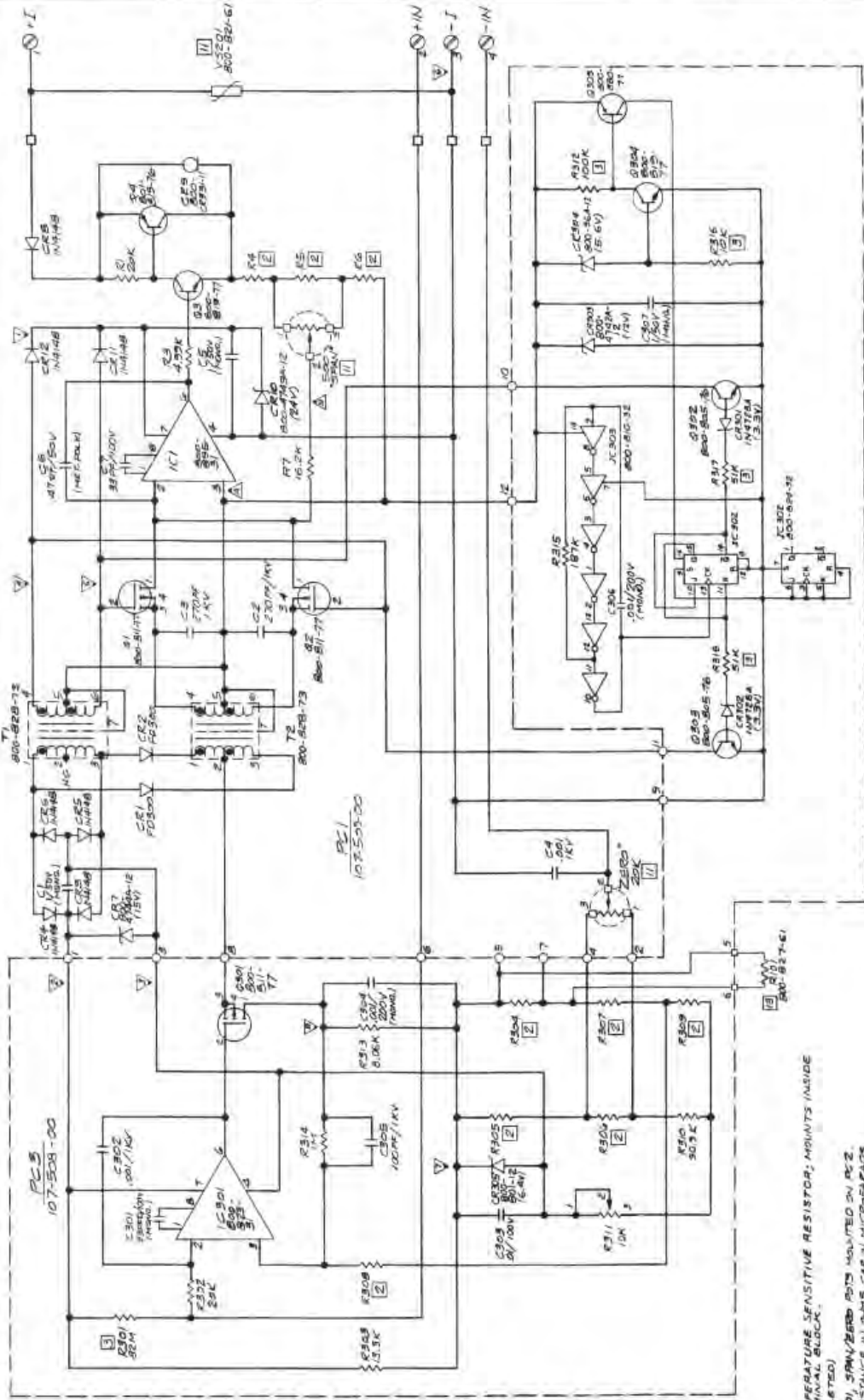

- Notes:
1. ALL RESISTORS ARE 1/4WATT UNLESS OTHERWISE SPECIFIED.
 2. CARBON COMPOSITION RESISTOR ± 10%, 1/4 W.
 3. SOLDER LIST ON MATERIALS FOR VALUE, PART NO AND/OR USAGE.
 4. POTENTIOMETER INCREASE CLOCKWISE RESIST 1 TO 3.
 5. SCREW TERMINAL CONNECTION.
 6. TEST POINT, REFER TO SECTION 5 OF MANUAL "MAINTENANCE".
 7. PC1/PC2 INTERCONNECT TO PIN.
 8. FLEX-JUMPER INTERCONNECT BETWEEN PC1 & PC3.
 9. RESISTANCE IN OHMS CAP IN MICROGRAMS.
 10. (DELETED)
 11. (DELETED)
 12. (DELETED)
 13. (DELETED)
 14. (DELETED)
 15. (DELETED)
 16. (DELETED)
 17. (DELETED)
 18. (DELETED)
 19. (DELETED)
 20. (DELETED)
 21. (DELETED)
 22. (DELETED)
 23. (DELETED)
 24. (DELETED)
 25. (DELETED)
 26. (DELETED)
 27. (DELETED)
 28. (DELETED)
 29. (DELETED)
 30. (DELETED)
 31. (DELETED)
 32. (DELETED)
 33. (DELETED)
 34. (DELETED)
 35. (DELETED)
 36. (DELETED)
 37. (DELETED)
 38. (DELETED)
 39. (DELETED)
 40. (DELETED)
 41. (DELETED)
 42. (DELETED)
 43. (DELETED)
 44. (DELETED)
 45. (DELETED)
 46. (DELETED)
 47. (DELETED)
 48. (DELETED)
 49. (DELETED)
 50. (DELETED)
 51. (DELETED)
 52. (DELETED)
 53. (DELETED)
 54. (DELETED)
 55. (DELETED)
 56. (DELETED)
 57. (DELETED)
 58. (DELETED)
 59. (DELETED)
 60. (DELETED)
 61. (DELETED)
 62. (DELETED)
 63. (DELETED)
 64. (DELETED)
 65. (DELETED)
 66. (DELETED)
 67. (DELETED)
 68. (DELETED)
 69. (DELETED)
 70. (DELETED)
 71. (DELETED)
 72. (DELETED)
 73. (DELETED)
 74. (DELETED)
 75. (DELETED)
 76. (DELETED)
 77. (DELETED)
 78. (DELETED)
 79. (DELETED)
 80. (DELETED)
 81. (DELETED)
 82. (DELETED)
 83. (DELETED)
 84. (DELETED)
 85. (DELETED)
 86. (DELETED)
 87. (DELETED)
 88. (DELETED)
 89. (DELETED)
 90. (DELETED)
 91. (DELETED)
 92. (DELETED)
 93. (DELETED)
 94. (DELETED)
 95. (DELETED)
 96. (DELETED)
 97. (DELETED)
 98. (DELETED)
 99. (DELETED)
 100. (DELETED)

DO NOT SCALE DRAWING	
TOLERANCES UNLESS NOTED:	DRAWN <i>D. [Signature]</i> 20 OCT 80 CHECKED ENGINEER SCALE 2/1
.X ±.1	
.XX ±.03	
.XXX ±.010	
ANGLES ±30'	

TCX
PCI

DRAWING NUMBER 107-505-00	REVISION G
CATEGORY ASSEMBLY	
REVISED BY ECO # 6405	DATE BY JAO APPROVAL

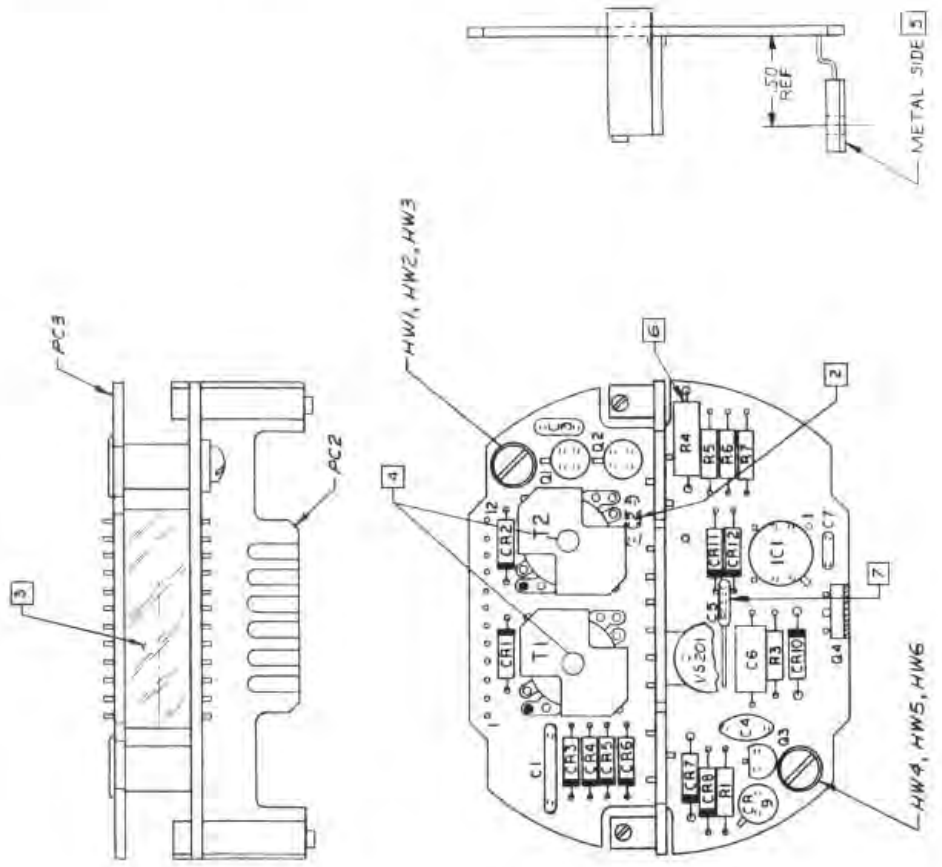

- 7 OFF SET C5 WITH SLEEVED LEAD TO CLEAR VS201.
- 6 ELL. FIT BODY OF R4 1/16 (MIN) ABOVE PC1.
- 5 BEND TRANSISTOR LEADS WITH TOOLING FIXTURE 200-213-11 BEFORE ASSEMBLY TO BOARD. USE TOOLING FIXTURE 200-213-10 TO HOLD TRANSISTOR IN PLACE WHEN SOLDERING, AS SHOWN IN SIDE VIEW.
- 4 INSTALL HW7, HW8 BETWEEN PC1 AND T1, T2.
- 3 FLEX JUMPER STRIP COMES WITH PCB, BEND INTO PLACE APPROX AS SHOWN.
- 2 C2 TO BE MOUNTED ON FAR SIDE.
- 1 ALL LEADS MUST BE SOLDERED TO PADS.

NOTES:

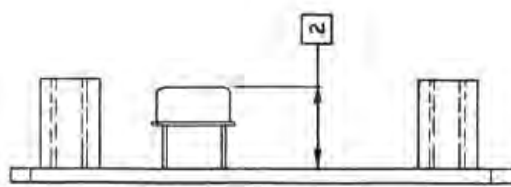
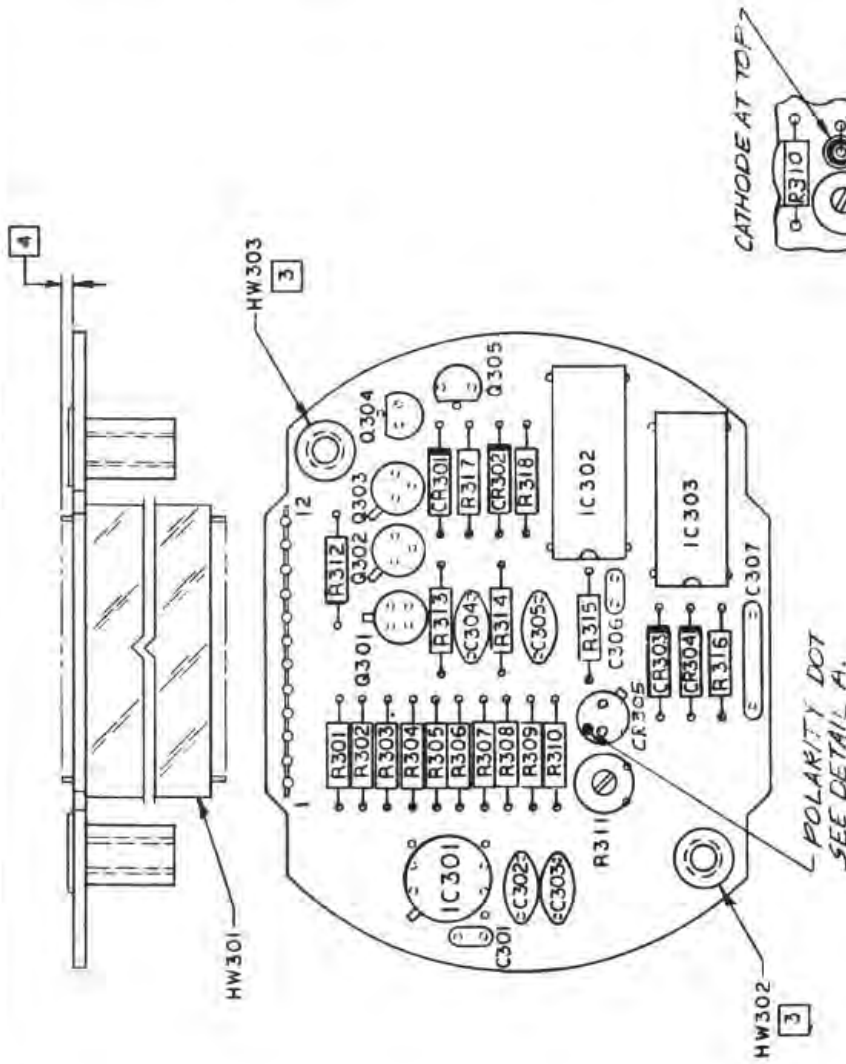

- 4 NOT TO EXCEED .05 AFTER INSTALLATION.
 - 3 SWAGE, FAR SIDE.
 - 2 MAX COMPONENT HEIGHT AFTER INSTALLATION NOT TO EXCEED .390.
- NOTES:
 1. ALL LEADS TO BE SOLDERED TO PADS.



MOORE INDUSTRIES
 16650 Schoenborn Street
 Sepulveda, California 91343

DO NOT SCALE DRAWING

TOLERANCES UNLESS NOTED
 .X ±.1
 .XX ±.03
 .XXX ±.010
 ANGLES ±30'

DRAWN G. T. SEEBER 1/24/78
 CHECKED 6/2/78
 ENGINEER

SCALE 2/1

DRAWING NUMBER 107-506-00
 CATEGORY ASSEMBLY
 REVISED BY INITIAL RELEASE
 DATE 5 OCT 81
 BY D
 REVISION A

TCX
 PC-2

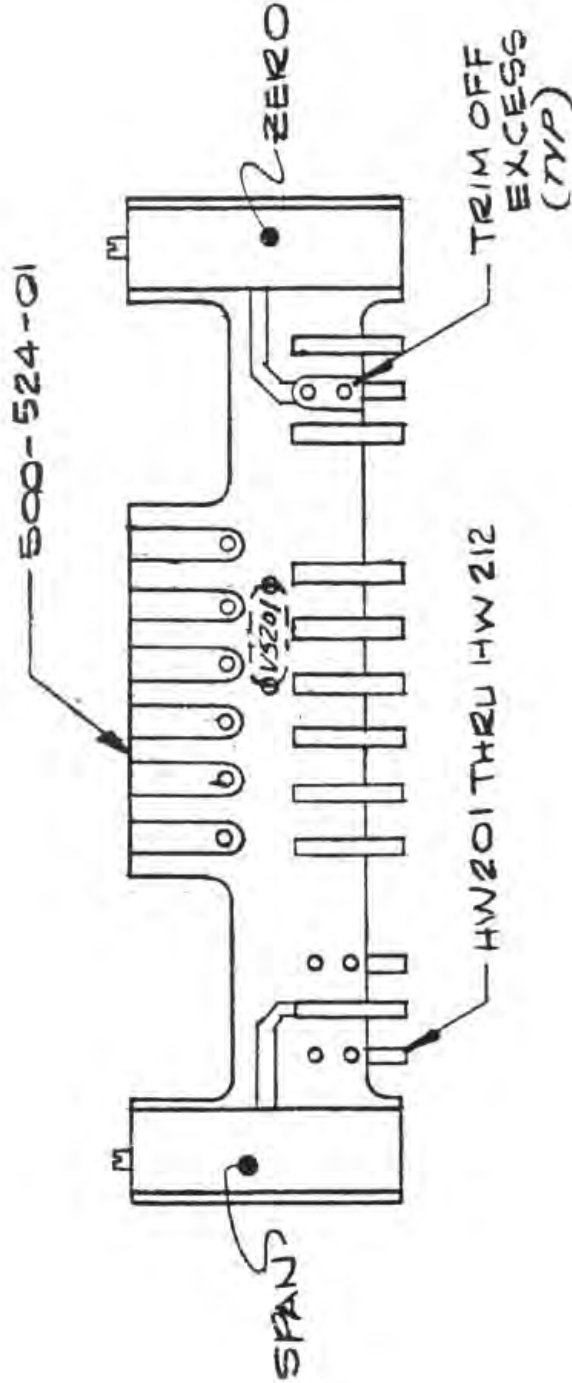

1. ALL LEADS MUST BE SOLDERED TO PADS.
 NOTES: UNLESS OTHERWISE SPECIFIED

REVISION
A

DRAWING NUMBER
107-507-00

CATEGORY
ASSEMBLY

REVISED BY
INITIAL RELEASE

DATE
OCT 8/6

BY
D

APPROVAL

TCX
PC2
--RF OPTION

DO NOT SCALE DRAWING

DRAWN
D. Martin
OCT 8/6

CHECKED

ENGINEER

SCALE
2/1

TOLERANCES
UNLESS NOTED

X ±.1

.XX ±.03

.XXX ±.010

ANGLES ±.30°

MOORE INDUSTRIES
16650 Schoenborn Street
Sepulveda, California 91343

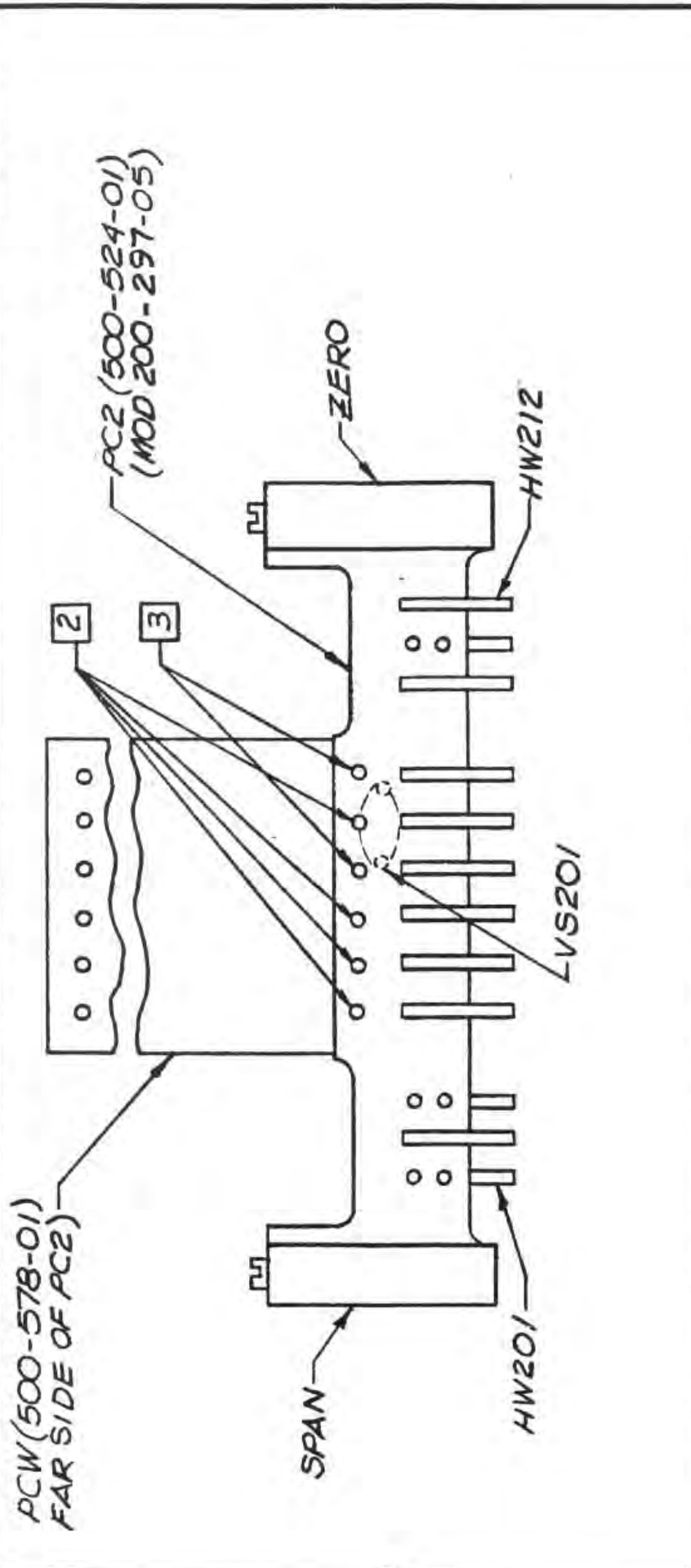

- [3] INSTALL VS201 LEADS THRU PC2 & PCW; SOLDER NEAR SIDE OF PC2 & FAR SIDE OF PCW.
 - [2] INSTALL 22 AWG BUSS WIRE THRU PC2 & PCW; SOLDER NEAR SIDE OF PC2 & FAR SIDE OF PCW.
1. DO NOT TRIM EXCESS FROM HW201 THRU HW212.
- NOTES:

DO NOT SCALE DRAWING

TOLERANCES
(UNLESS NOTED)
X ±.1
XX ±.03
XXX ±.010
ANGLES ±30°

DRAWN A. PAPUC 1/83
CHECKED
DESIGNED
SCALE NONE

TCX
PLUG-IN
PC

DRAWING NUMBER
107-451-00

REVISION
D

CATEGORY
SCHEMATIC

REVISED BY
E.D. GISS

DATE 1-18-83 BY JMM APPROVAL

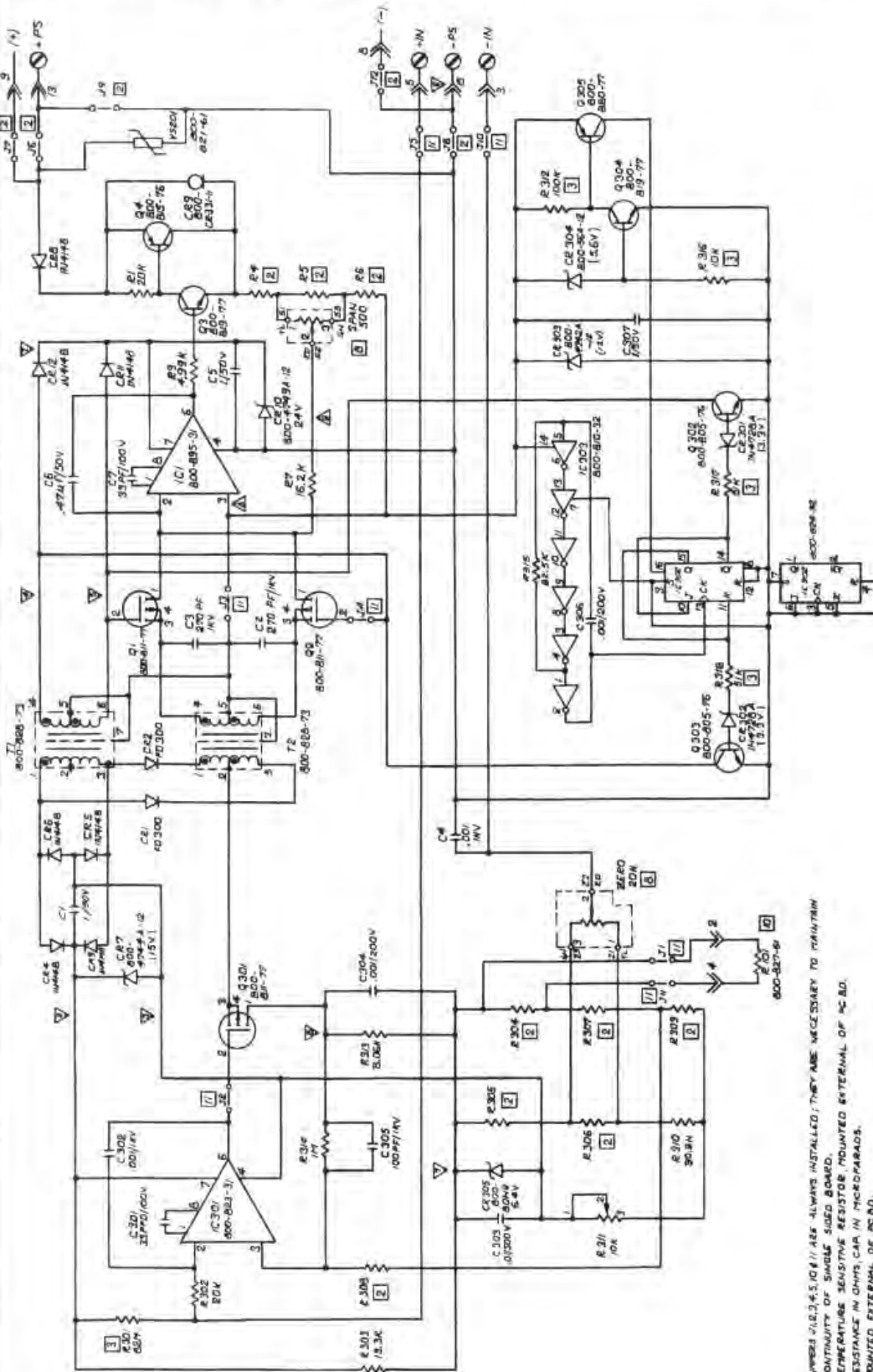

- NOTES:
1. DIMENSIONS 1, 2, 3, 4, 5, 10, 11 ARE ALWAYS INSTALLED, THEY ARE NECESSARY TO MAINTAIN CONTINUITY OF SINGLE SIDED BOARD.
 2. TEMPERATURE SENSITIVE RESISTORS, MOUNTED EXTERNAL OF PC BO.
 3. RESISTANCE IN OHMS, CAP IN MICROFARADS.
 4. MOUNTED EXTERNAL OF PC BO.
 5. 0 INDICATES WIRING PWD ON PC BO.
 6. 010 POINT, REFER TO SECTION 5 OF MANUAL "MAINTENANCE".
 7. 010 SCREW TERMINAL CONNECTION.
 8. POSITIONING METERS INCREASE CLOCKWISE FROM PIN 1 TO PIN 3.
 9. CARBON COMPOSITION RESISTOR 20%, 1/4 W.
 10. SEE LIST OF MATERIALS FOR VALUES, PART NO. AND/OR USAGE.
 11. ALL RESISTORS ARE RN 55C METAL FILM 1%, 1/8 WATT.
 12. UNLESS OTHERWISE SPECIFIED.

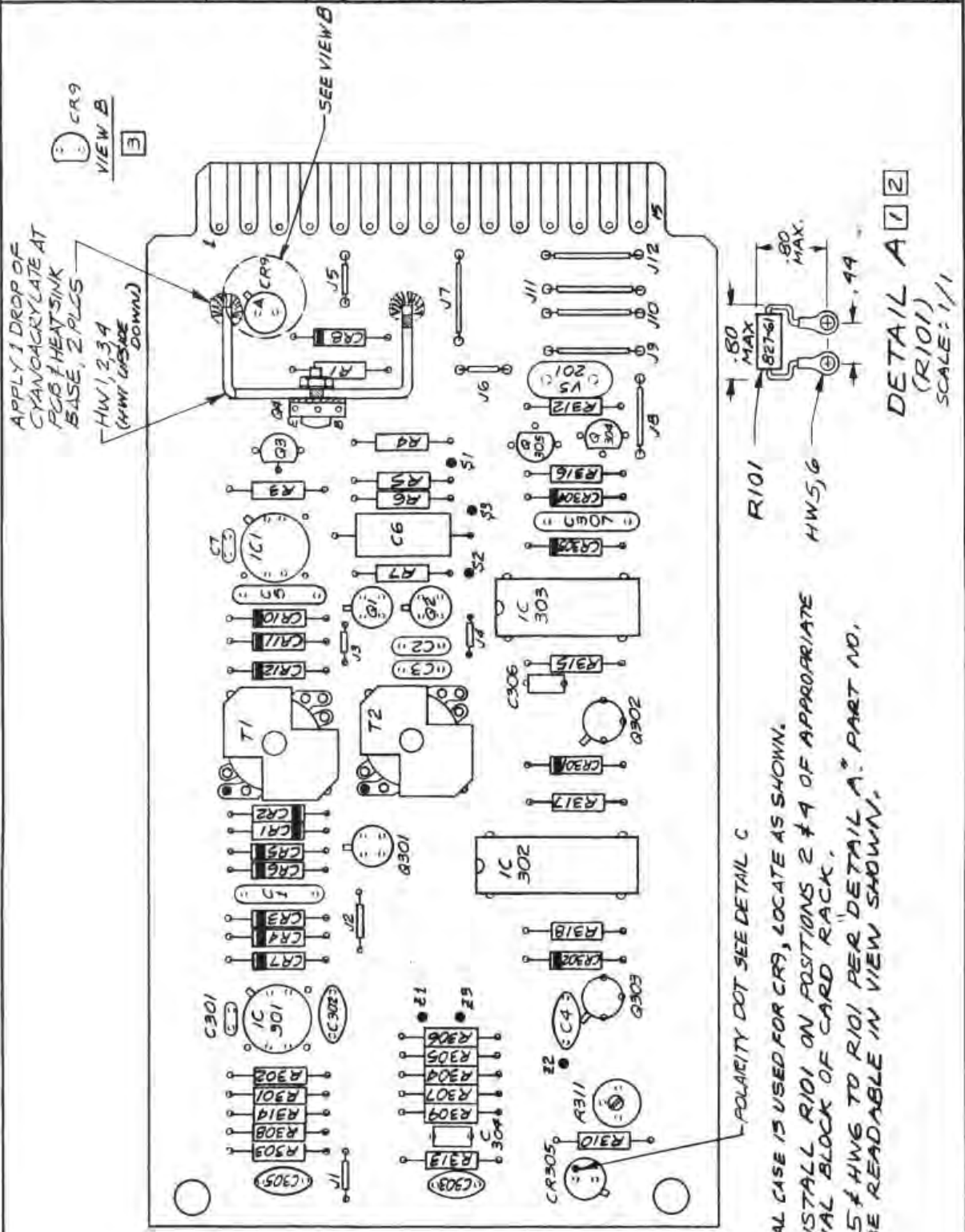

APPLY 1 DROP OF
CYANOACRYLATE AT
PCB HEAT-SINK
BASE, 2 PLCS
HW 1, 2, 3, 4
(HW OPPOSITE
DOWN)

CR9
VIEW B

SEE VIEW B

POLARITY DOT SEE DETAIL C

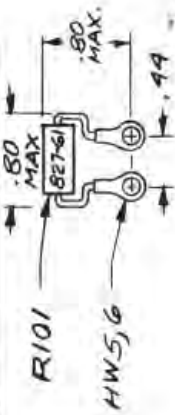

DETAIL A [1] [2]
(R101)
SCALE: 1/1



DETAIL C

ALTERNATE CR305

- NOTES:
- 3 IF OPTIONAL CASE IS USED FOR CR9, LOCATE AS SHOWN.
 - 2 REF.: INSTALL R101 ON POSITIONS 2 & 4 OF APPROPRIATE TERMINAL BLOCK OF CARD RACK.
 - 1 ADD HW5 & HW6 TO R101 PER "DETAIL A." PART NO. SHOULD BE READABLE IN VIEW SHOWN.

RETURN PROCEDURES

To return equipment to Moore Industries for repair, follow these four steps:

1. Call Moore Industries and request a Returned Material Authorization (RMA) number.

Warranty Repair –

If you are unsure if your unit is still under warranty, we can use the unit's serial number to verify the warranty status for you over the phone. Be sure to include the RMA number on all documentation.

Non-Warranty Repair –

If your unit is out of warranty, be prepared to give us a Purchase Order number when you call. In most cases, we will be able to quote you the repair costs at that time. The repair price you are quoted will be a "Not To Exceed" price, which means that the actual repair costs may be less than the quote. Be sure to include the RMA number on all documentation.

2. Provide us with the following documentation:
 - a) A note listing the symptoms that indicate the unit needs repair
 - b) Complete shipping information for return of the equipment after repair
 - c) The name and phone number of the person to contact if questions arise at the factory
3. Use sufficient packing material and carefully pack the equipment in a sturdy shipping container.
4. Ship the equipment to the Moore Industries location nearest you.

The returned equipment will be inspected and tested at the factory. A Moore Industries representative will contact the person designated on your documentation if more information is needed. The repaired equipment, or its replacement, will be returned to you in accordance with the shipping instructions furnished in your documentation.

WARRANTY DISCLAIMER

THE COMPANY MAKES NO EXPRESS, IMPLIED OR STATUTORY WARRANTIES (INCLUDING ANY WARRANTY OF MERCHANTABILITY OR OF FITNESS FOR A PARTICULAR PURPOSE) WITH RESPECT TO ANY GOODS OR SERVICES SOLD BY THE COMPANY. THE COMPANY DISCLAIMS ALL WARRANTIES ARISING FROM ANY COURSE OF DEALING OR TRADE USAGE, AND ANY BUYER OF GOODS OR SERVICES FROM THE COMPANY ACKNOWLEDGES THAT THERE ARE NO WARRANTIES IMPLIED BY CUSTOM OR USAGE IN THE TRADE OF THE BUYER AND OF THE COMPANY, AND THAT ANY PRIOR DEALINGS OF THE BUYER WITH THE COMPANY DO NOT IMPLY THAT THE COMPANY WARRANTS THE GOODS OR SERVICES IN ANY WAY.

ANY BUYER OF GOODS OR SERVICES FROM THE COMPANY AGREES WITH THE COMPANY THAT THE SOLE AND EXCLUSIVE REMEDIES FOR BREACH OF ANY WARRANTY CONCERNING THE GOODS OR SERVICES SHALL BE FOR THE COMPANY, AT ITS OPTION, TO REPAIR OR REPLACE THE GOODS OR SERVICES OR REFUND THE PURCHASE PRICE. THE COMPANY SHALL IN NO EVENT BE LIABLE FOR ANY CONSEQUENTIAL OR INCIDENTAL DAMAGES EVEN IF THE COMPANY FAILS IN ANY ATTEMPT TO REMEDY DEFECTS IN THE GOODS OR SERVICES. BUT IN SUCH CASE THE BUYER SHALL BE ENTITLED TO NO MORE THAN A REFUND OF ALL MONIES PAID TO THE COMPANY BY THE BUYER FOR PURCHASE OF THE GOODS OR SERVICES.

ANY CAUSE OF ACTION FOR BREACH OF ANY WARRANTY BY THE COMPANY SHALL BE BARRED UNLESS THE COMPANY RECEIVES FROM THE BUYER A WRITTEN NOTICE OF THE ALLEGED DEFECT OR BREACH WITHIN TEN DAYS FROM THE EARLIEST DATE ON WHICH THE BUYER COULD REASONABLY HAVE DISCOVERED THE ALLEGED DEFECT OR BREACH, AND NO ACTION FOR THE BREACH OF ANY WARRANTY SHALL BE COMMENCED BY THE BUYER ANY LATER THAN TWELVE MONTHS FROM THE EARLIEST DATE ON WHICH THE BUYER COULD REASONABLY HAVE DISCOVERED THE ALLEGED DEFECT OR BREACH.

RETURN POLICY

For a period of thirty-six (36) months from the date of shipment, and under normal conditions of use and service, Moore Industries ("The Company") will at its option replace, repair or refund the purchase price for any of its manufactured products found, upon return to the Company (transportation charges prepaid and otherwise in accordance with the return procedures established by The Company), to be defective in material or workmanship. This policy extends to the original Buyer only and not to Buyer's customers or the users of Buyer's products, unless Buyer is an engineering contractor in which case the policy shall extend to Buyer's immediate customer only. This policy shall not apply if the product has been subject to alteration, misuse, accident, neglect or improper application, installation, or operation. THE COMPANY SHALL IN NO EVENT BE LIABLE FOR ANY INCIDENTAL OR CONSEQUENTIAL DAMAGES.



WORLDWIDE • www.miinet.com

United States • info@miinet.com Tel: (818) 894-7111 • FAX: (818) 891-2816	Belgium • info@mooreind.be Tel: 03/448.10.18 • FAX: 03/440.17.97	China • sales@mooreind.sh.cn Tel: 86-21-62491499 • FAX: 86-21-62490635
Australia • sales@mooreind.com.au Tel: (02) 8536-7200 • FAX: (02) 9525-7296	The Netherlands • sales@mooreind.nl Tel: (0)344-617971 • FAX: (0)344-615920	United Kingdom • sales@mooreind.com Tel: 01293 514488 • FAX: 01293 536852